

# Multi objective Control Strategy Using Distributed Generation Inverter For Power Quality Improvement

Priya M Patil, Manjappa N.

**Abstract-** power quality plays a vital role as electricity will be marketed based on the same in this competitive environment. The presence of nonlinear loads and power electronic equipment leads to a major power quality issue in a grid. This paper deals with a multiobjective control strategy for current controlled dg inverter. The dg inverter incorporates active filter functionality in forward and reverse power flow modes when connected to a nonlinear load. It also deals with compensation of current harmonics, reactive power and unbalance mitigation of active power of the power distribution system through closed loop power control strategy. A hysteresis band current controller is used to generate the switching pulses for the interfaced inverter. Extensive simulation studies are done in matlab/simulink software to validate the effectiveness of the proposed control strategy.

**Keywords-** renewable energy sources (RES), distributed generation (DG), multifunctional grid connected inverter (MFGCI), power quality enhancement, power quality total harmonic distortion (THD).

## 1 INTRODUCTION

Due to the growing importance of renewable-energy-based power generation, a large number of power electronics interfaced dg units have been installed in the low-voltage power distribution systems. It has been reported that the control of interfacing converters can introduce system resonance issues. Moreover, the increasing presence of nonlinear loads will further degrade distribution system power quality [1]. The power quality requirement is always challenging the secure, stable, effective, and economic operation of micro-grids. Firstly, the parallel and/or series harmonic resonances may result in undesired trips of grid-tied inverters, and may even lead to some cascading failures secondly, the harmonic and reactive current flowing across the micro-grid will cause extra power loss and lower the usage capacity of lines and loads. Particularly, the harmonic can cause vibration and noise of electric machines and transformers [9]. Finally, poor power quality will lead to poor on-grid electricity price in a power quality sensitive market in the future. Recently, the multi-functional grid-tied inverter (MFGTI) has been considered as a solution with high cost-effectiveness. The so-called mfgti is an advanced grid-tied inverter which can not only interface RERS into utility, but also enhance the power quality at its grid-tied point. On one hand, the grid-tied inverters have the same power conversion topologies as the ones of power quality conditioners, such as active power filters (APFS), static VAR generators (SVGS), etc. On the other hand, in general, the capacity of

photovoltaic arrays and/or wind turbines. Thus, it can adapt the stochastic and intermittent features of solar irradiation and/or wind speed.

Additionally, the grid-tied inverters cannot always operate at their nominal capacity points. Thus, the surplus capacity of a grid-tied inverter is available in most of its operation time. Therefore, the grid-tied inverters have the additional capacity that can be utilized to enhance the power quality at their grid-tied points, in such a way that no extra power quality conditioner may be needed in an inverter-dominated micro-grid. An electrical distribution system is subjected to power fluctuations and uncertainties which causes the voltage at point of common coupling (PCC) to be unbalanced. The interaction between the dg inverter nonlinear current and distorted PCC voltages may contribute power control errors in the steady state. Hence closed loop power control strategy is necessary for accurate power tracking in the case of distorted voltages at the PCC. The objective of is to develop a control strategy for harmonic current filtering in a three phase grid connected dg system without using extra compensating device. In this paper we proposed a design of multipurpose control strategy for VSC used in dg system. The idea is to integrate the dg resources to the power grid. The proposed VSC controls the injected active power flow from the dg source to the grid and also performs the compensation of reactive power and the nonlinear load current harmonics, keeping the grid current almost sinusoidal.

---

Department of EEE, University Visvesvaraya College Of Engineering,  
Bengaluru, India

a grid-tied inverter is larger than that of the installed

The rest of the paper is organized into four sections. Section ii gives proposed dg model. Generation of the reference currents for the proposed method is dealt in

section iii. Section iv relates to the simulation results for different operating modes of the dg inverter under various load and supply conditions. Conclusion is given in section v.

## 2 PROPOSED DG MODEL

A schematic representation of the proposed system is given in fig.1. Rg and lg represents the grid resistance and Inductance up to the point of common coupling; rdg and ldg Represents the equivalent resistance and inductance of the Inverter filter, coupling transformer and connecting cables; ls represents the smoothing inductance inserted in series with the Load to reduce the spikes in the grid current due to switching Transients; va, vb, vc represents the voltages at the pcc and ila, ilb, ilc represents the load currents.

## 3 VOLTAGE AND CURRENT COMPONENTS IN D-Q REFERENCE FRAME

The control technique employed is based on the analysis of load voltage, load current and inverter currents in the dq synchronous rotating frame. Independent control of active and reactive power can be achieved with more effectiveness in dq frame. The instantaneous angle of the voltage at pcc is obtained by using a phase locked loop (pll).

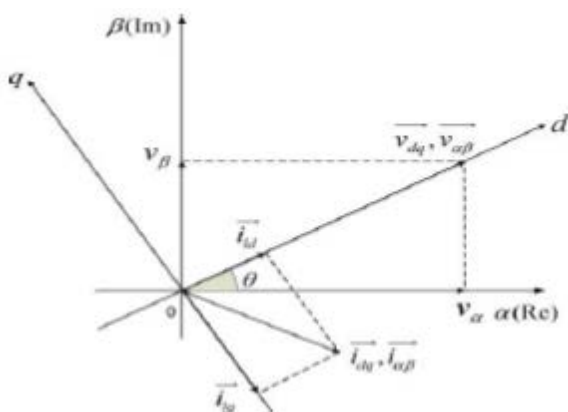

Fig.1 voltage and current components in d-q frame  
The clarke transformation maps the three-phase Instantaneous voltages and currents in the 123 phases Into the instantaneous voltages and currents on the  $\alpha\beta$ -axes. In the next step, the  $\alpha\beta$  reference frame is transformed to the Rotating synchronous reference frame, i.e., in dq-components. The synchronous reference frame uses a reference frame transformation module, to transform the grid current and voltage waveforms into a reference frame that rotates synchronously with the grid voltage. By means of this, the control variables become dc values; thus, filtering and controlling can be achieved easily. Fig. 1 shows the voltage and current components in  $\alpha\beta$  and dq reference frames. Considering d-axis vector in the direction of voltage vector in this transformation, the

q-component of voltage in rotating synchronous reference frame is always zero ( $v_q = 0$ ) .according to fig. 1, the magnitude of the voltage at the pcc can be calculated as

$$v_{ref} = |\vec{v}_d| = |\vec{v}_{dq}| = |\vec{v}_{\alpha\beta}| = \sqrt{v_\alpha^2 + v_\beta^2}$$

A) calculation of d-axis and q-axis reference currents to supply load active and reactive power  
The active and reactive power injected from the dg link to the grid at the fundamental frequency is

$$P_{dg} = \frac{3}{2} (v_d I_{dgd} + v_q I_{dqg})$$

$$Q_{dg} = \frac{3}{2} (v_q I_{dgd} - v_d I_{dqg})$$

Where idgd and idgqq and are the dq- components of dg Inverter current at fundamental frequency to manage active and reactive power exchange between the grid and res. Vd and vq are the pcc voltages in dq frame.

The currents at fundamental frequency required to deliver The active and reactive power from the res has to be supplied by the dg inverter. The corresponding reference currents at

Fundamental frequency are  $i^*_{dgd}$  and  $i^*_{dgq}$ , which can be Calculated using the open loop and the proposed closed loop Power control strategy as explained below.

1) open loop power control

In a practical case, the pcc voltages may contain ripple due To the unexpected power fluctuations and excessive use of harmonic polluted loads connected to the system. Hence to generate the fundamental current components, the pcc voltages are filtered in dq frame[13]

Using equations (1) and (2)

$$\begin{bmatrix} I^*_{dgd} \\ I^*_{dgq} \end{bmatrix} = \frac{1}{\tilde{v}_d^2 + \tilde{v}_q^2} \begin{bmatrix} P^* & Q^* \\ -Q^* & P^* \end{bmatrix} \begin{bmatrix} \tilde{v}_d \\ \tilde{v}_q \end{bmatrix} \frac{2}{3} \quad (3)$$

Where vd and vq are the voltages after passing through a low pass filter. P\* and q\*are the active and reactive power references.

Fig.2 schematic diagram of proposed dg system

2) proposed closed loop power control

In the proposed closed loop control strategy, the calculated dg active and reactive power are filtered through a low pass fiiter and compared with the reference powers to get the error signal. The dq - components of

inverter reference current at fundamental frequency can be generated by passing the error signal through a pi controller and can be expressed as

$$I_{dgd}^* = (P^* - P_{dg}) \left( k_{p1} + \frac{k_{i1}}{s} \right) \quad (4)$$

$$I_{dgg}^* = (Q^* - Q_{dg}) \left( k_{p2} + \frac{k_{i2}}{s} \right) \quad (5)$$

Where pdg and qdg represent the filtered real and reactive power of the dg inverter, kpi .kil, kp2 and kil are the proportional and integral gains for minimizing the real and reactive power control errors

As per IEEE 1547 the inverters in a distributed Generation system are not permitted to inject reactive power to the grid[5]. As such, the total q-axis reference current for the inverter is limited to meet only the reactive power demand of the load so that  $i_{dgg}^* = 0$ . Hence only active power control is done in both open loop and closed loop control schemes.

In rotating synchronous frame the quadrature component of Load current  $i_{lq}$  is perpendicular to the direct component of Voltag [12]. Accordingly the q-axis reference current Of the dg inverter can be expressed as

$$I_{dgg}^* = i_{lg} \quad (6)$$

B. Calculation of total d-axis reference current The d-axis component of the load current can be expressed As [12]

$$I_{ld} = i_{ld1} + i_{ld} \quad (7)$$

Where  $i_{ld}$  is the oscillating component of the load current And  $i_{ld1}$  is the fundamental component of load current. In dq Frame the fundamental frequency component of the load Current appears as a dc component. The harmonic components Of the load current can be obtained by using a high pass filter. But due to the excessive phase lag associated with the high Pass filter, a second order low pass filter having a cut off Frequency of 25 hz is used to extract the harmonic component Of the load current.

$I_{ld}$  can be expressed as

$$\tilde{i}_{ld} = \sum_{n=2}^{\infty} i_{ldn} \quad (8)$$

$$\sum_{n=2}^{\infty} i_{ldn} = i_{ld} (1 - LPF) \quad (9)$$

The dg inverter has to supply the d-axis component of Harmonic load current given by equation (8) and the d-axis Component of current at fundamental frequency given by Equation (3) or (4) depending upon the type of the power Control scheme. Hence the total d-axis reference current for the Dg inverter can be expressed as

$$i_{dgd}^* = \tilde{i}_{ld} + I_{dgd}^* \quad (10)$$

### C. Dc link voltage control

When the power from the res is equal to zero, the inverter Operates in shunt active filter mode. The do inverter draws an Active power component of current  $i_{dc}$  for maintaining the dc Bus voltage constant and to meet the losses in the inverter. The Dc link voltage error can be expressed as

$$v_{dcerr} = v_{dc}^* - v_{dc} \quad (11)$$

The current  $i_{dc}$  can be obtained by passing the error through A pi controller and is given by

$$i_{dc} = k_p v_{dcerr} + k_i \int v_{dcerr} dt \quad (12)$$

Where  $k_p$  and  $k_i$  are the proportional and integral gain constants.

### D. Hysteresis current control scheme

A hysteresis band current controller is used to generate the Switching pulses for the dg inverter. The reference currents Generated in dq frame are transformed to natural abc frame and Compared with the inverter currents to generate the error Signals.

If  $i_{dga} - i_{dga} > hb$ , then upper switch is switched on and lower switch is switched off in the inverter leg of phase 'a'.

If  $i_{dga} - i_{dga} < hb$ , then upper switch is switched off and Lower switch is switched on in the inverter leg of phase 'a', Where  $hb$  is the assigned hysteresis band. Using the same Principle switching pulses for the other switches in phase 'b' & 'C' are produced. The hysteresis band directly controls the

Amount of ripples in the current injected into the grid. The main Advantages of hysteresis current controller are ease of Implementation, extremely good dynamic response, Outstanding robustness and independence of load parameter Changes [17]. The switching frequency depends on the width of Hysteresis band, the size of interfacing inductor  $L_d$  to the grid, And the dc voltage. As per [18], the relation between Switching frequency and the filter inductance can be expressed As

Where  $v_{dc}$  is the dc link voltage,  $hb$  is the hysteresis band and  $f_{swmax}$  is the maximum switching frequency.

## 4 SIMULATION RESULTS

To verify the effectiveness and validity of the proposed Technique, detailed simulations are done for various load Conditions in mat ab isimulink environment using power System blockset. The schematic of the control block diagram Is given in fig.2. The inverter has got a power rating of 20 Kva and the maximum available active power

from the dg is 8kw [18]. The active power reference is taken as 8kw in Simulation and is assumed to be constant for all load Conditions. The capability of the dg inverter to function as an Active power filter is examined first by putting the reference Active power as zero. Next the performance of the do inverter In the forward and reverse power flow modes in the ideal Supply voltage conditions are analyzed using the closed loop Active power control. The effectiveness of the proposed closed Loop control strategy is compared with open loop control under The non-ideal supply conditions at the end. The parameters used for simulation are given in table i.

Table i.  
 Simulation parameters

Parameter	Value
Grid voltage	400v
Grid resistance	0.01ohm
Grid inductance	0.15mH
DC link voltage set point	800v
DC link capacitance	3000microF
Interfacing resistance	0.15ohm
Interfacing inductance	5.5mH
Nonlinear load	25/50ohm, 10mH
Smoothing filter inductance	1mH

A. Shunt active filter mode (pref=0).

When there is no power from the res the dg inverter Operates in shunt active filter mode. The performance of the System with an unbalanced nonlinear load is shown in fig.3. After the connection of dg at t=0.02 second, the grid currents Are balanced and sinusoidal with a total harmonic distortion (thd) of 0.9, 0.89 & 0.91 in phases a, b and c. The dc voltage Is maintained at the reference value of 800v as shown in fig.4

B. Forward power flow mode (pref<pl)

The dg link dc voltage is assumed constant in this mode In order to evaluate the capability of the proposed control Strategy for accurate power tracking. A three phase diode Rectifier feeding a load of resistance of 25ohm and an inductance of 15mh is connected to the pcc. The nonlinear load currents make the grid currents highly polluted. The dg inverter is connected to the grid at t=0.06 second. The nonlinear part of the load current is supplied by the dg inverter and the grid Currents become sinusoidal. Since the load power is greater Than the maximum power

capacity pre! Of the inverter, the grid Also supplies positive power to the load as shown in fig.5

(a).the grid voltage which is exactly in phase with the grid Current is shown in fig.6 (a), which indicates an improvement In the input power factor.

C. Reverse power flow mode (pref>pl)

The resistance of the nonlinear load is increased to 50ohm in Order to reduce the load power than the reference active power Of the dg. Figure 5(b) indicates negative grid power, which Means that the excess power from the dg is fed back to the Grid during this mode. The grid currents are exactly out of Phase with the grid voltage as shown in fig. 6 (b). The thd of The grid currents are well maintained within the ieee limits as Given in table. Ii. In all the three modes of operation, the reactive power demand of the load is met by the dg inverter and the reactive power supplied by the grid Becomes zero as shown in fig. 5 (c).

Table ii

Thd of grid currents under ideal supply conditions

Mode of operation	Before compensation			After Compensation		
	$I_{ga}$	$I_{gb}$	$I_{gc}$	$I_{ga}$	$I_{gb}$	$I_{gc}$
Forward power flow	26.49	26.49	26.49	2.4	2.4	2.4
Reverse power flow	27.84	27.84	27.84	3.9	4	3.9

D. Unbalanced and distorted supply

An unbalanced three phase supply can be represented using Positive and negative sequence components. The presence of negative sequence components in the voltage causes power control errors which cannot be addressed in an open loop power control. To evaluate the effectiveness of the proposed method, the supply voltages are modified by introducing 10% unbalance with 3% third and fifth harmonics. The performance of the inverter is analyzed using the open loop and proposed closed loop power control strategy. The supply voltage is made unbalanced and distorted at t=0.02 sec. The grid currents are balanced and sinusoidal as shown in fig.7. Figure 8 shows that the closed loop power control strategy is able to track the active power reference with zero steady state errors. With closed loop control, the ripples in the injected fundamental current of dg inverter is reduced as shown in fig. 9. The distortion in the grid currents is also less than that of open loop control and a comparative analysis of thd is given in table iii.



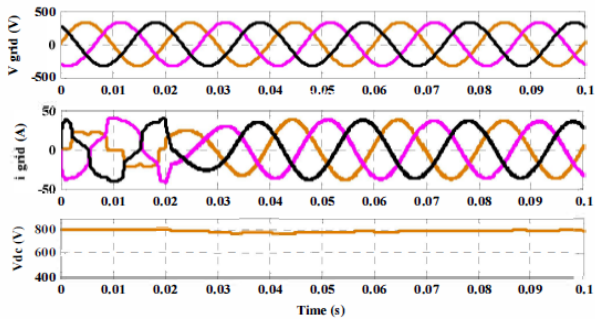

Fig.4 grid voltage, grid currents and dc link voltage during Shunt active filter mode of the dg inverter

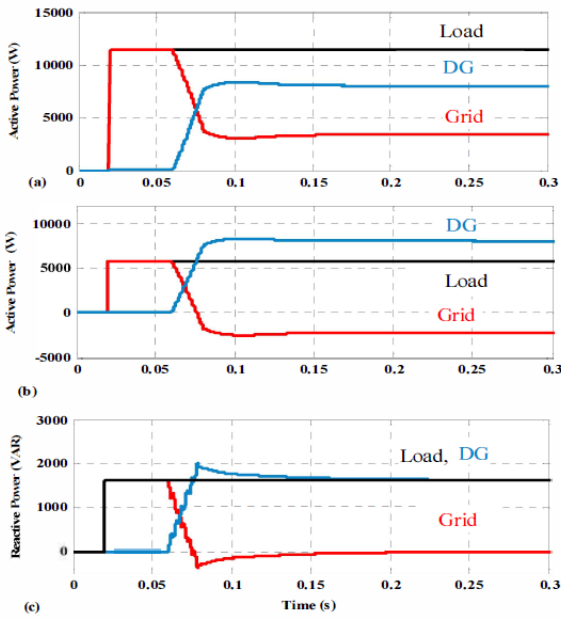

Fig. 5 grid, dg and load active power in a) forward power Flow mode, b) reverse power flow mode and c) reactive power in both modes.

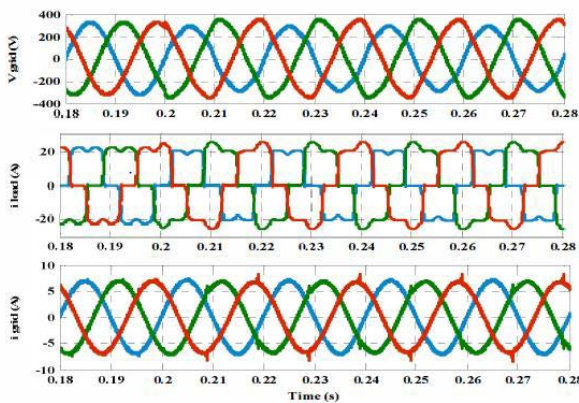

Fig.7 grid voltage, load and grid currents under unbalanced and distorted Supply voltages with closed loop power control

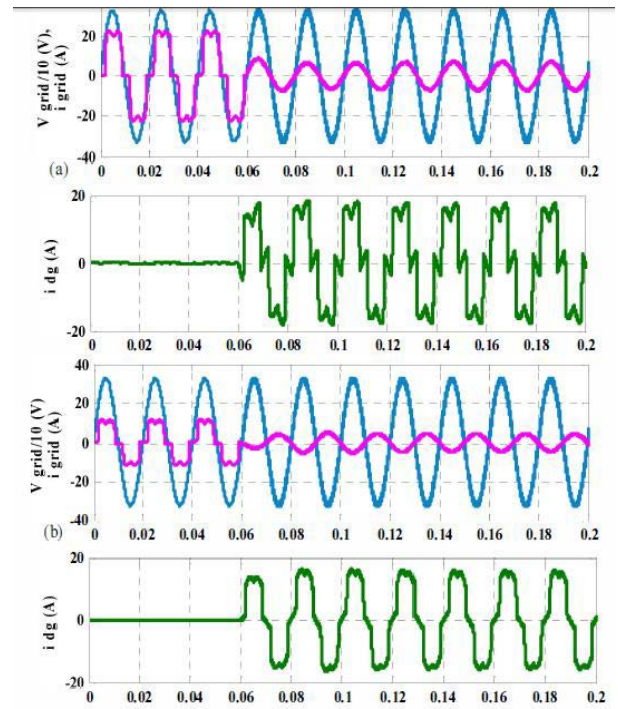

Fig. 6 grid voltage, grid current and dg current in phase 'a' under a) forward b) reverse power flow modes

Table iii

Thd of grid currents under unbalanced and distorted

Mode of operation	Before compensation			After Compensation		
	$I_{ga}$	$I_{gb}$	$I_{gc}$	$I_{ga}$	$I_{gb}$	$I_{gc}$
Forward power flow	26.49	26.49	26.49	2.4	2.4	2.4
Reverse power flow	27.84	27.84	27.84	3.9	4	3.9

## 5 CONCLUSION

This paper discusses the capabilities of a mfgci for Enhancing the power quality in a grid connected distributed Generation system. It has been shown that the dg inverter can Be effectively utilized to inject real power from the res in the Forward and reverse power flow modes and/or operate as a Shunt active power filter. The proposed closed loop active Power control strategy achieves accurate power tracking with Zero steady state errors under ideal and non-ideal supply

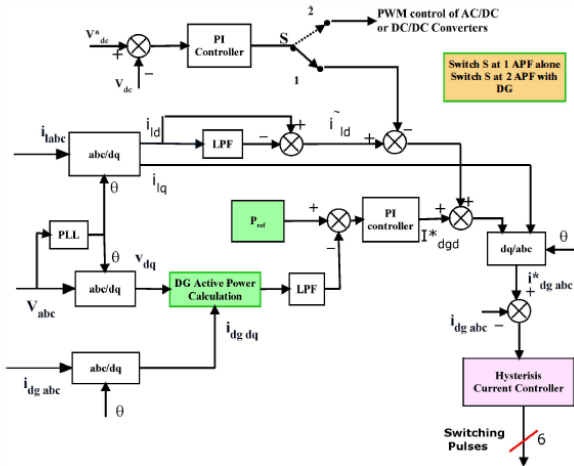

Fig.3 control block diagram for generation of switching pulses for the dg inverter.

Conditions and can be used as a control technique for Integration of dg inverters to the utility grid. The method Eliminates the need of extra power conditioning devices to Improve the power quality. The effectiveness of the control Scheme is verified under balanced and unbalanced nonlinear Load conditions. With the proposed method the combination of Nonlinear loads and the dg inverter is seen as a resistive load At the pcc and the grid currents are maintained sinusoidal supply condition.

**REFERENCES**

[1] F. Blaabjerg, R. Teodorescu, M. Liserre, And Adrian V. Timbus, " Overview Of Control And Grid Synchronization For Distributed Power Generation Systems," Ieee Trans. Ind. Electron., Vo1.53, No.5, Pp.1398-1409, Oct. 2006  
 [2] J. Rocabert, A. Luna, F. Blaabjerg And P.Rodrigues, "Control Of Power Converters In Ac Microgrids," Ieee Trans. Power Electron., Vol. 27, No. 11, Pp.4734-4748, Nov. 2012  
 [3] I.Ei-Samahy And E.Ei-Saadany, "The Effect Of Dg On Power Quality In A Deregulated Environment," In Proc. Ieee Pesgm. 2005, Pp. 2969-2976  
 [4] F. Blaabjerg, Z. Chen, And S. Kjaer, "Power Electronics As Efficient Interface In Dispersed Power Generation Systems," Ieee Trans. Power Electron.,Vol. 19,No. 5, Pp. 1184-1194, Sep. 2004.  
 [5] Ieee Standard For Interconnecting Distributed Resources With Electric Power Systems, Ieee Std. 1547, 2003.  
 [6] S.Rahmani, N. Mendalek, K. Ai-Haddad, "Experimental Design Of A Nonlinear Control Technique For Three Phase Shunt Active Power Filter," Ieee Trans. Ind. Electron, Voi.57,No.Lo,Oct 2010.

[7] N. Pogaku And T.C.Green, "Harmonic Mitigation Throughout A Distribution System- A Distributed Generator Based Solution," Lee Proc. Gener. Transm. Distrib, Vol. I 53, No.3, Pp. 350-358, May 2006.  
 [8] Z. Zeng, H.Yang, R. Zhao And C. Cheng, " Topologies And Control Strategies Of Multifunctional Grid Connected Inverters For Power Quality Enhancement: A Comprehensive Review, Renewable And Sustainable Energy Reviews,24, Pp 223-270, 2013.  
 [9] C.L Gajanayake, D.M. Vilathgamuwa, P.C. Loh, R. Teodorescu And F. Blaabjerg, " Z-Source -Inverter-Based Flexible Distributed Generation System Solution For Grid Power Quality Improvement," Ieee Trans. Energy Conv, Vol. 24,No.3, Pp. 695-704, Sept.2009.  
 [10] J. He, Y.W. Li, F. Blaabjerg, " Flexible Microgrid Power Quality Enhancement Using Adaptive Hybrid Voltage And Current Controller." Ieee Trans. Ind. Electron. Vol. 61. No.6. June 2014.  
 [11] M. Singh, S. Member, V. Khadkikar, A. Chandra, And S. Member, "Grid Interconnection Of Renewable Energy Sources At The Distribution Level With Power-Quality Improvement Features," Ieee Trans. Power Delivery Vol. 26, No. I, Pp. 307-315, 2011.  
 [12] E. Pouresmaeil, C. M - Espinar, M. M - Campos, D. M- Miracle And O. G -Bellmunt, "A Control Technique For Integration Of dg Units To The Electrical Networks," Ieee Trans. Power Electron., Vol. 60, No. 7, Pp. 2881-2893, July 2013.  
 [13] Z. Zeng, H Yang, Q Tang, R Zhao, " Objective-Oriented Power Quality Compensation Of Multifunctional Grid -Tied Inverters And Its Application In Microgrids," Ieee Trans. Power Electron., Vo1.30, No.3, Pp. 1255-1265, March 2015.  
 [14] 1 He, Y.Wei Li, F.Blaabjerg, X.Wang, "Active Harmonic Filtering Using Current-Controlled Grid - Connected Dg Units With Closed Loop Power Control," Ieee Trans. Power Electron., Vol. 29, No. 2, Pp. 642-653, Feb. 2014.  
 [15] H.Akagi, E.H. Watanabe,And M.Aredes, Instantaneous Power Theory And Applications To Power Conditioning, Hoboken, Nj: Wiley-Ieee Press, Feb. 2007.  
 [16] R. Teodorescu, M. Liserre, And P.Rodriguez, Grid Converters For Photovoltaic And Wind Power Systems, Ieee Wiley, 2011.  
 [17] Marian P, Kazmierkowski, And Luigi Malesani, " Current Control Techniques For Three-Phase Voltage - Source Pwm Converters: A Survey," Ieee Transactions On Industrial Electronics, Vol. 45, No.5, Pp.691-702, Oct. 1998.  
 [18] E. Pouresmaeil, M.F. Akorede, M- Miracle And O. G - Bellmunt And J.C.T. Caballero, "Hysteresis Current Control Technique Of Vsi For Compensation Of Grid-Connected Unbalanced Loads," Electrical Engineering 96.1 (2014), Pp.27-35. 210